



COTTON ROW MULCHER

The innovative C&M Cotton Row Mulcher delivers increased cotton mulching productivity like no other.

Using a unique, patented design, this machine features 12 x single row mulching heads, enabling operators to mulch 12 rows in one pass – at higher speeds.

Make post-harvest cotton stubble mulching faster and more productive with this quality Australian-made and designed speciality implement.

FEATURES & BENEFITS

- 12 x single row mulching heads
- Designed for Category 3 and 4 quick-hitch
- Heavy-duty construction
- Adjustable ground clearance with hydraulic and / or manual controls
- Walking beam wheels

Collier & Miller 12 Row Linkage
Product Code: CMCRM



COLLIER & MILLER



SCAN FOR
MORE INFO

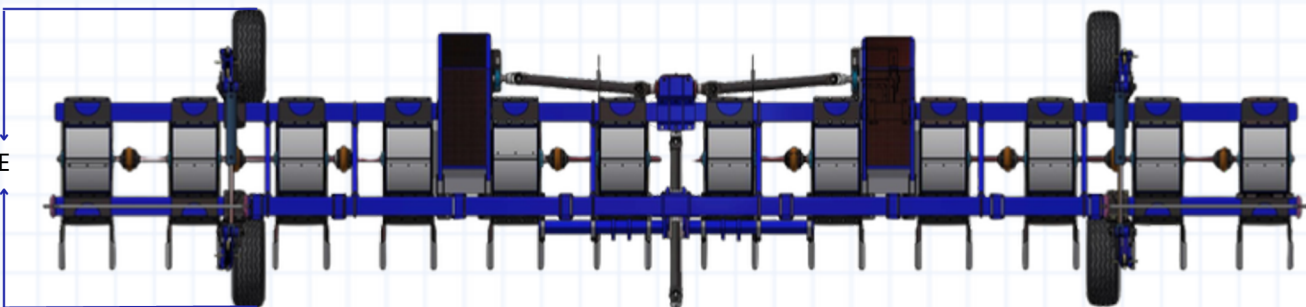
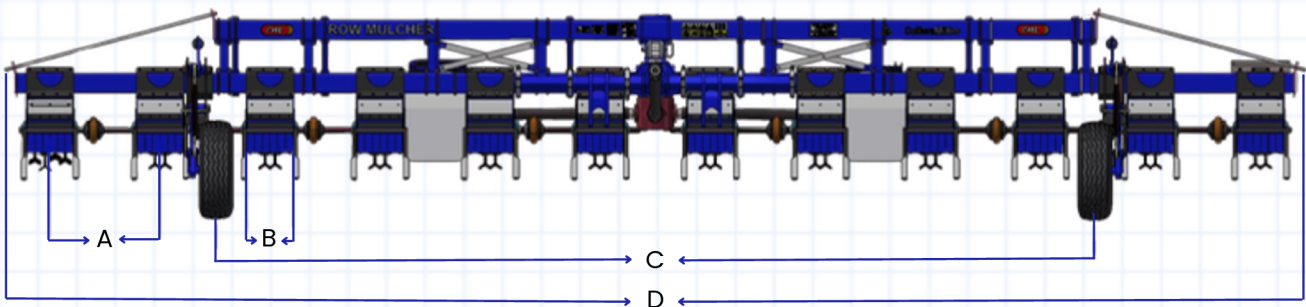
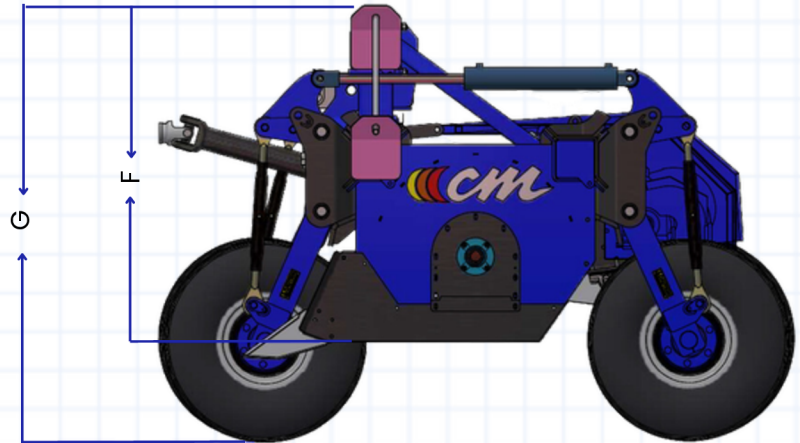

MODEL	CMCRM
DESCRIPTION	C&M Cotton Mulcher 12 Row Linkage Mounted
NUMBER OF ROWS	12
A = ROW SPACING	1m
B = MULCHING UNIT WIDTH	420mm
C = LIFT WHEEL SPACING	8,000mm
D = OVERALL WIDTH	11,820mm
E = MAX WIDTH	3,280mm
F = MIN HEIGHT	1,480mm
G = MAX HEIGHT	1,920mm
OVERALL WEIGHT	8,050kg